

# Table of Contents

	PAGE
<b>General Mounting</b>	
Standard.....	270
Reversible Clamp.....	271
Linear.....	272
Rotary.....	273
Retrofit Brackets.....	275
<b>Operation</b>	
Electrical.....	276
Mechanical.....	277
<b>Wiring</b>	
General.....	278
Accessories.....	279
<b>Startup and Checkout</b> .....	<b>282</b>

### General Information

#### Preliminary Steps

1. Belimo actuators with NEMA 1 or NEMA 2 ratings should be mounted indoors in a dry, relatively clean environment free from corrosive fumes. If the actuator is mounted outdoors, a protective enclosure must be used to shield the actuator.
2. For new construction work, order dampers with extended shafts. Instruct the installing contractor to allow space for mounting the Belimo actuator on the shaft.

#### For replacement of existing gear train actuators, there are two options:

- A. From a performance standpoint, it is best to mount the actuator directly onto the damper shaft.
- B. If the damper shaft is not accessible, mount the non-spring return actuator with a ZG-NMA or ZG-GMA crank arm kit, and a mounting bracket (ZG-100, ZG-101, ZG-103, ZG-104)

### Determining Torque Loading and Actuator Sizing

Damper torque loadings, used in selecting the correct size actuator, should be provided by the damper manufacturer. If this information is not available, the following general selection guidelines can be used.

Damper Type	Torque Loading
Opposed blade, without edge seals, for non-tight close-off applications	3 in-lb/sq. ft.
Parallel blade, without edge seals, for non-tight close-off applications	4 in-lb/sq. ft.
Opposed blade, with edge seals, for tight close-off applications	5 in-lb/sq. ft.
Parallel blade, with edge seals, for tight close-off applications	7 in-lb/sq. ft.

The above torque loadings will work for most applications under 2 in. w.g. static pressure or 1000 FPM face velocity. For applications between this criteria and 3 in. w.g. or 2500 FPM, the torque loading should be increased by a multiplier of 1.5. If the application calls for higher criteria up to 4 in. w.g. or 3000 FPM, use a multiplier of 2.0.

#### Torque Loading Chart

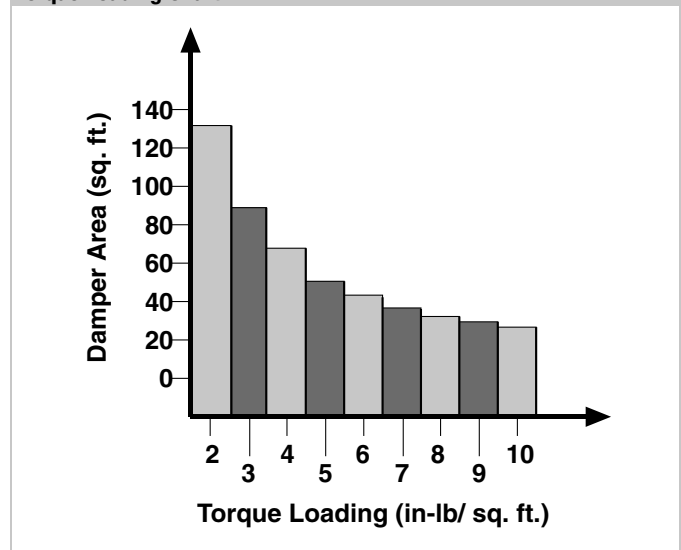

### Multiple Actuator Mounting

If more torque is required than one GM can provide, GM24B, GMB24-SR or GMX24-MFT may be installed on the same shaft.

# Installation Instructions

## Quick-Mount Visual Instructions for Mechanical Installation

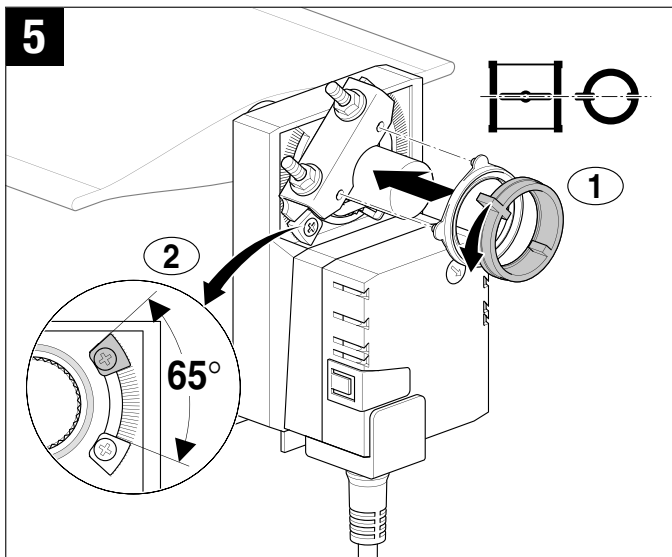
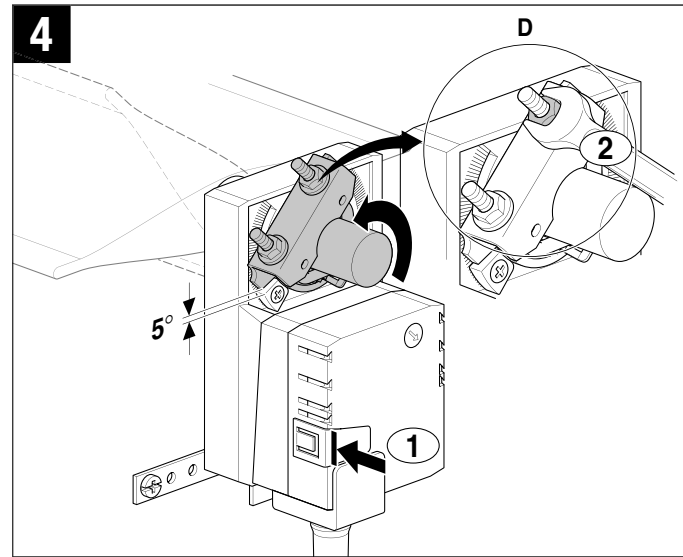
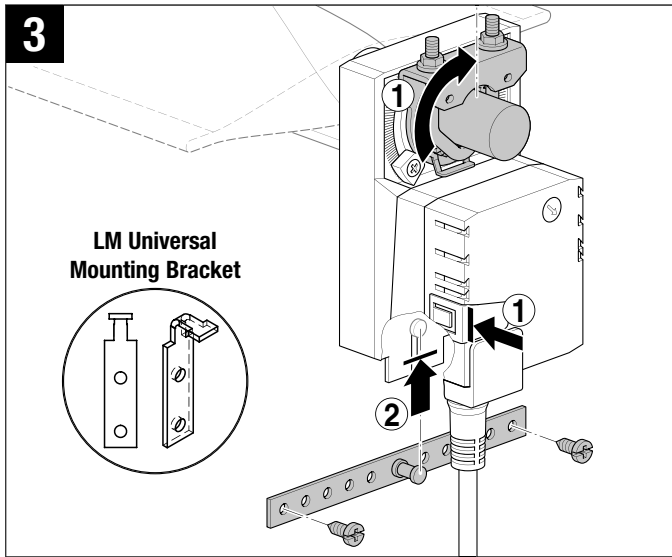
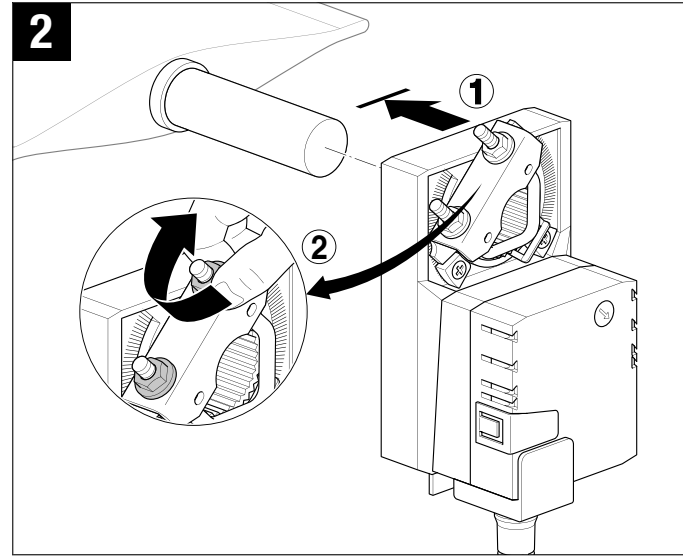
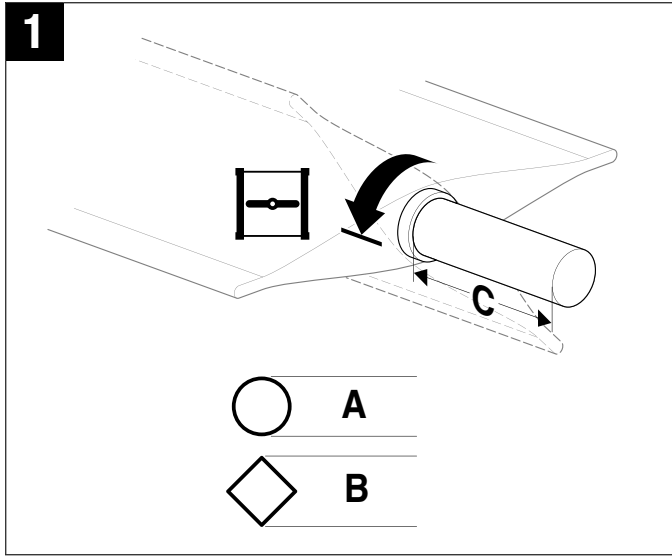

SEE NEXT PAGE FOR STANDARD MOUNTING INSTRUCTIONS.

	A*	B	C**	D
<b>LMB</b>	1/4" to 5/8"	5/16" to 9/16"	1.5"	4 to 5 ft-lb
<b>LMQB</b>	1/2" to 1.05"	3/8" to 11/16"	1.5"	6 to 7 ft-lb
<b>NMB</b>	1/2" to 1.05"	3/8" to 11/16"	1.5"	6 to 7 ft-lb
<b>NMQB</b>	1/2" to 1.05"	3/8" to 11/16"	1.5"	6 to 7 ft-lb
<b>AMB</b>	1/2" to 1.05"	3/8" to 11/16"	1.5"	6 to 7 ft-lb
<b>AMQB</b>	1/2" to 1.05"	7/16" to 11/16"	1.5"	6 to 7 ft-lb
<b>GMB</b>	1/2" to 1.05"	7/16" to 11/16"	1.5"	6 to 7 ft-lb

\* LMB standard clamp has max 5/8" diameter. Accessory clamp K-LM20 can be mounted for sizes up to 3/4" diameter. NM and AM clamps have an insert that self-centers on the following diameter shafts: 1/2" (default), 3/4" and 1.05". GM clamps have an insert that self-centers on 3/4" diameter.

\*\* Shorter with reversible clamp for NMB, AMB, and GMB.

M40024 - 05/10 - Subject to change. © Belimo Aircontrols (USA), Inc.

#### Standard Mounting

- 1** Turn the damper shaft until the blades are fully closed.
- 2**
  - ① Slip the actuator's universal clamp over the damper shaft. Make sure that the duct and the controls on the cover are accessible. Place the actuator in the desired mounting position.
  - ② Hand tighten the two nuts on the actuators universal clamp.
- 3**
  - ① Disengage the actuator gear train by pressing the manual override button and rotate the clamp until centered.
  - ② Slide the anti-rotation strap up under the actuator so it engages the actuator at the center cutout. Bend the bracket as needed to support the rear of the actuator. Secure to ductwork with self-tapping screws (No. 8 recommended).
- 4**
  - ① Loosen the nuts on the universal clamp. Press the manual override button and rotate the clamp to about 5° from the closed position (1/16 to 1/8" between stop and clamp).
  - ② Tighten the two nuts on the universal clamp with a 10 mm wrench (see table for required torque).
- 5**
  - ① Snap on the reflective position indicator.
  - ② Adjust end-stops, if required.
- 6** Mount actuators indoors. If mounted outdoors, use approved protective enclosure.

The damper is now fully closed but the actuator is 5° from fully closed. This is called "pre-loading" the actuator. When the actuator is powered and sent to the closed position: it will put its full torque on the shaft compressing the edge and blade seals. This ensures that the damper will meet its leakage rating. The actuator is electronically protected from overload and will not be damaged.

#### Testing the Installation Without Power

1. Disengage the gear train with the manual override button and move the shaft from closed to open to closed. Ensure that there is no binding and that the damper goes fully open and closes with 5° of actuator stroke left.
2. Correct any problems and retest.

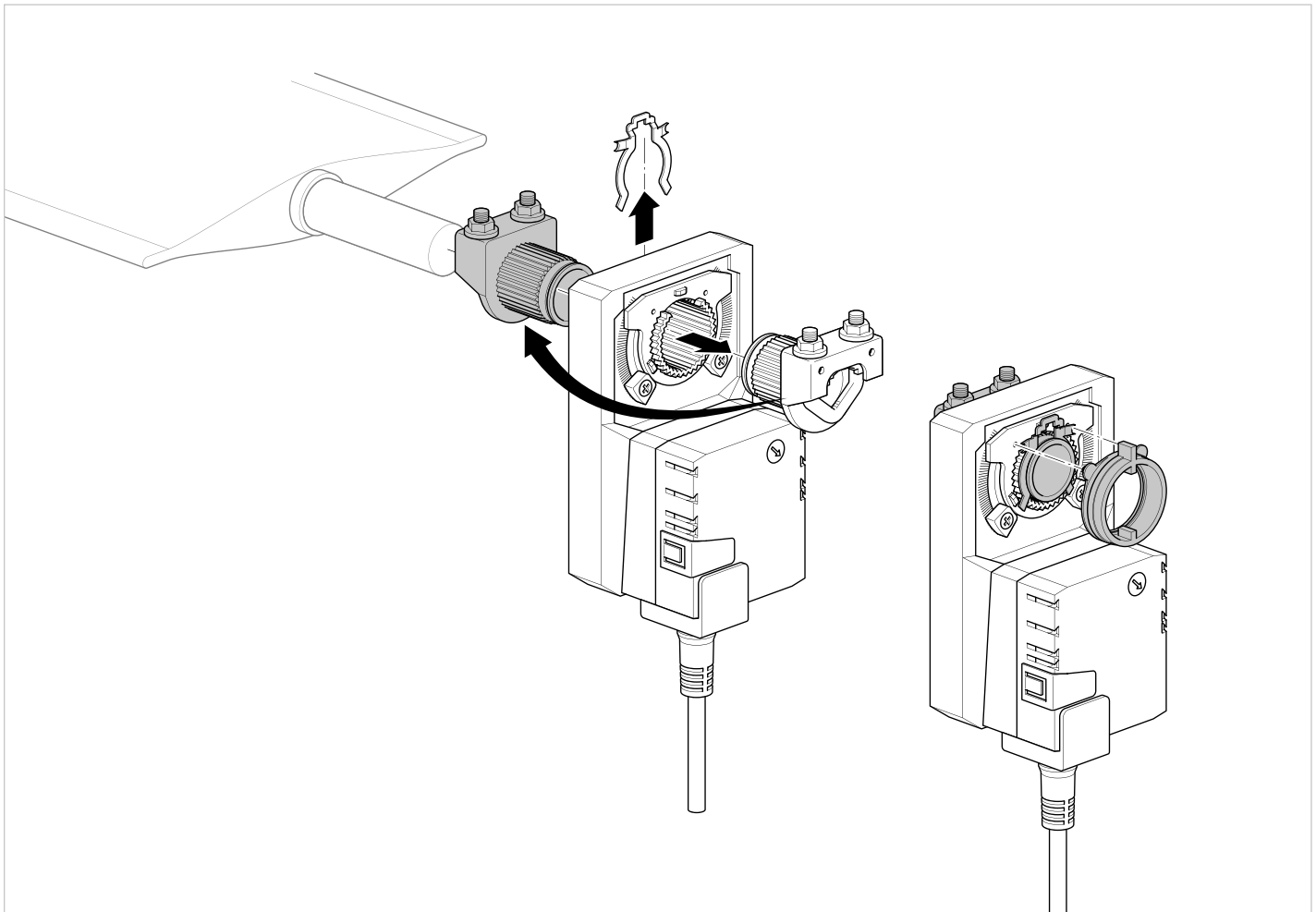

# Mounting Installation

Linear Quick Mount (LH, AH)

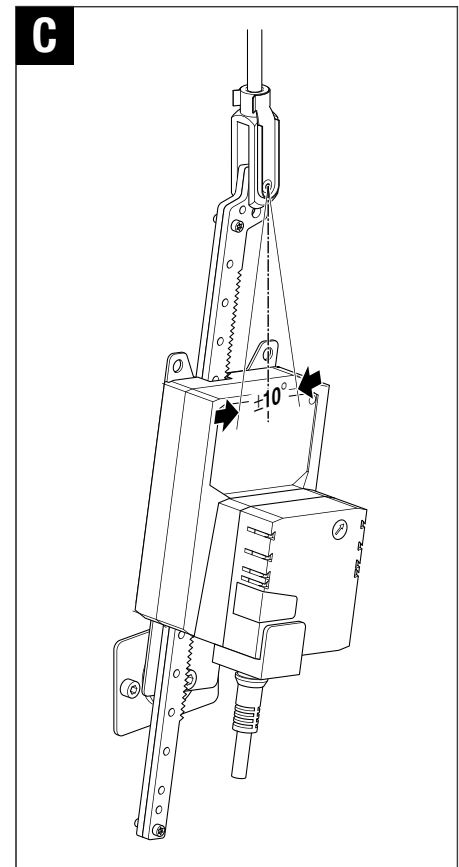
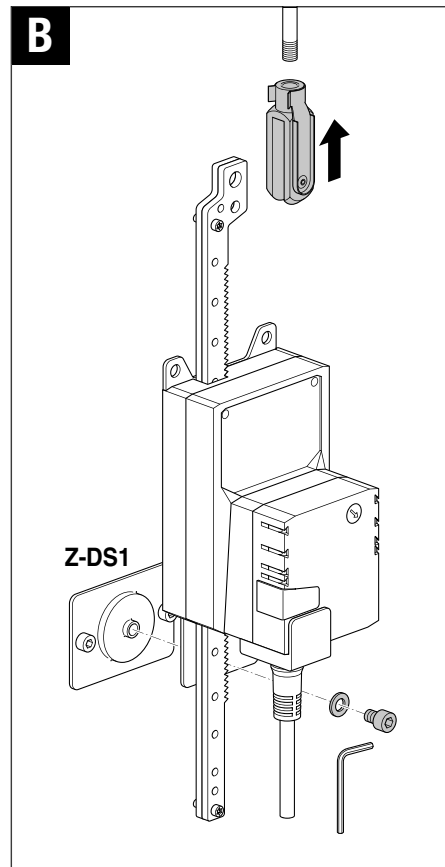
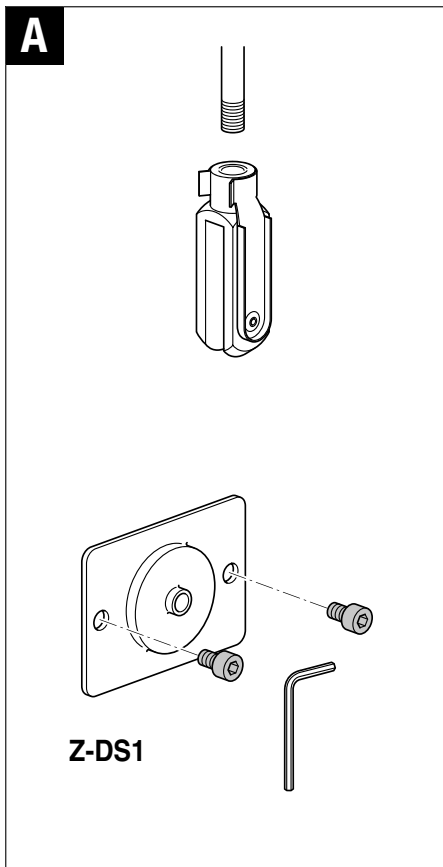
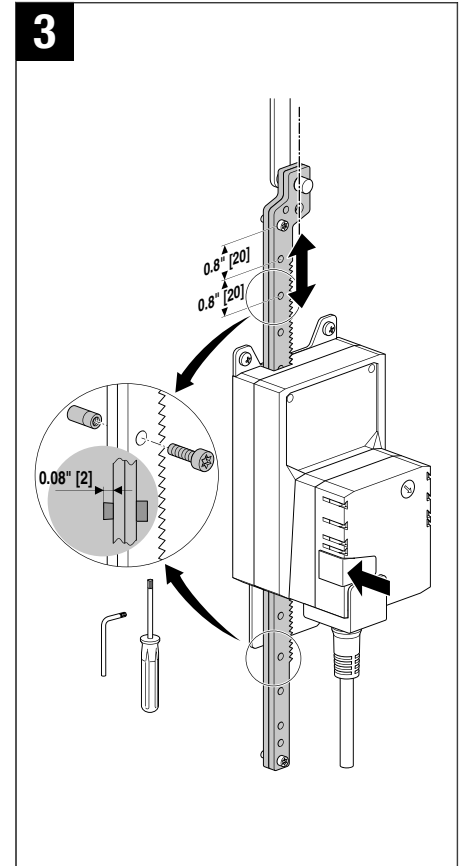
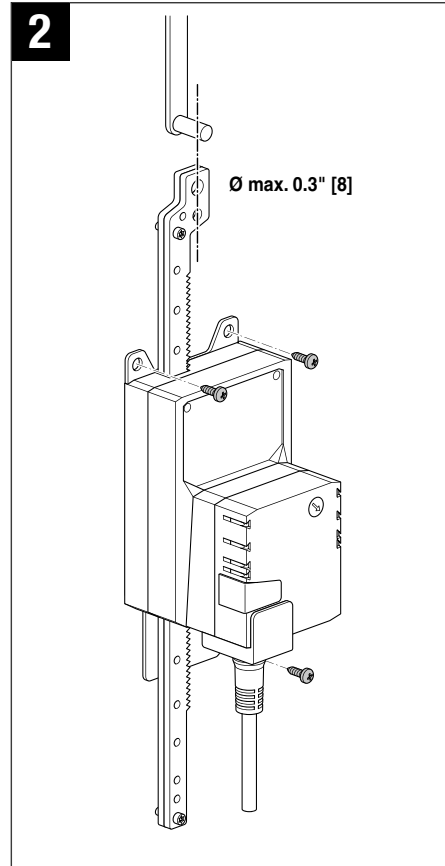
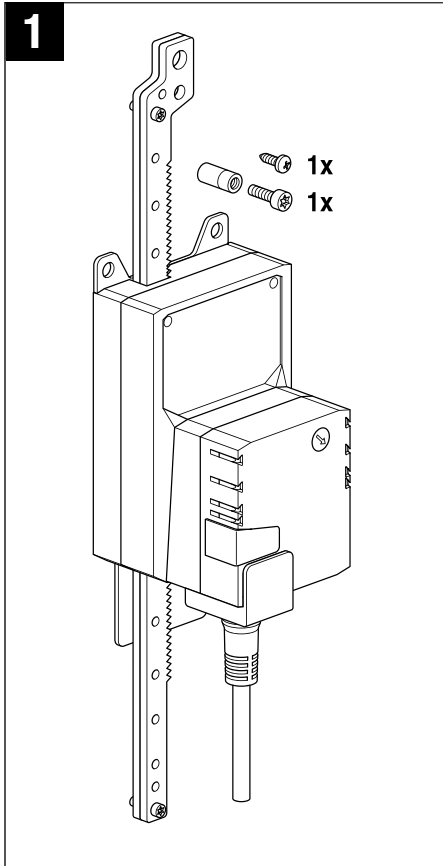

M40024 - 05/10 - Subject to change. © Belimo Aircontrols (USA), Inc.

**K-LU Shaft Clamp**

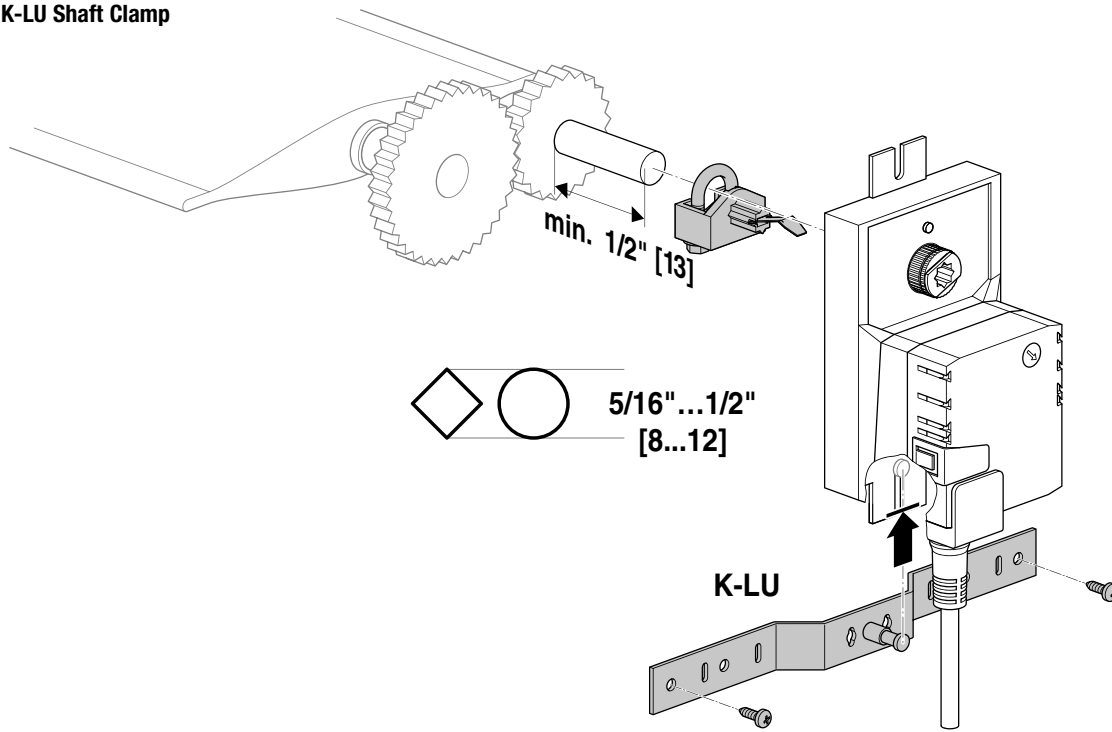

**ZDB-LU Angle of Rotation Limiter**

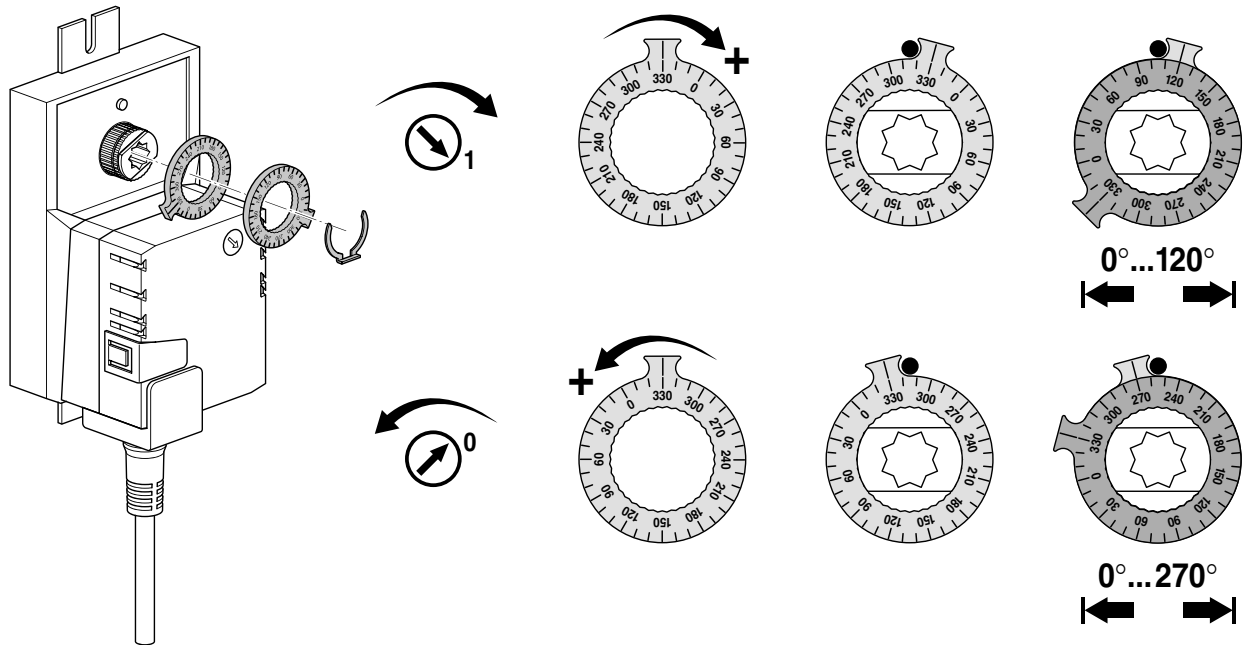

M40024 - 05/10 - Subject to change. © Belimo Aircontrols (USA), Inc.

# Mounting Installation

Quick Mount, Direct Coupled CMB24-3(-T) / CMB120-3

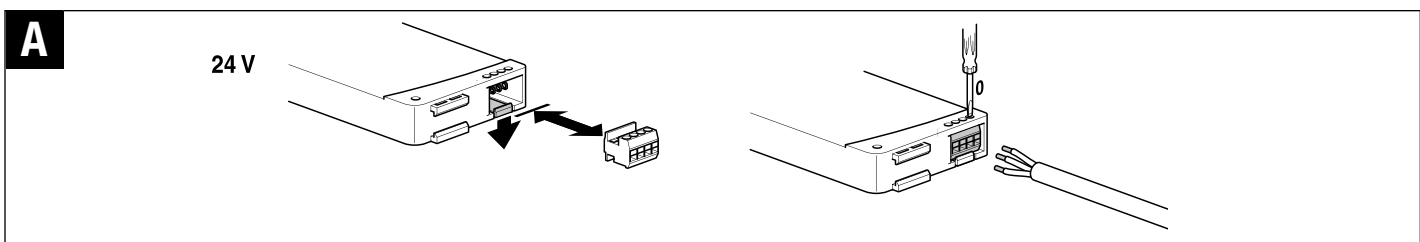
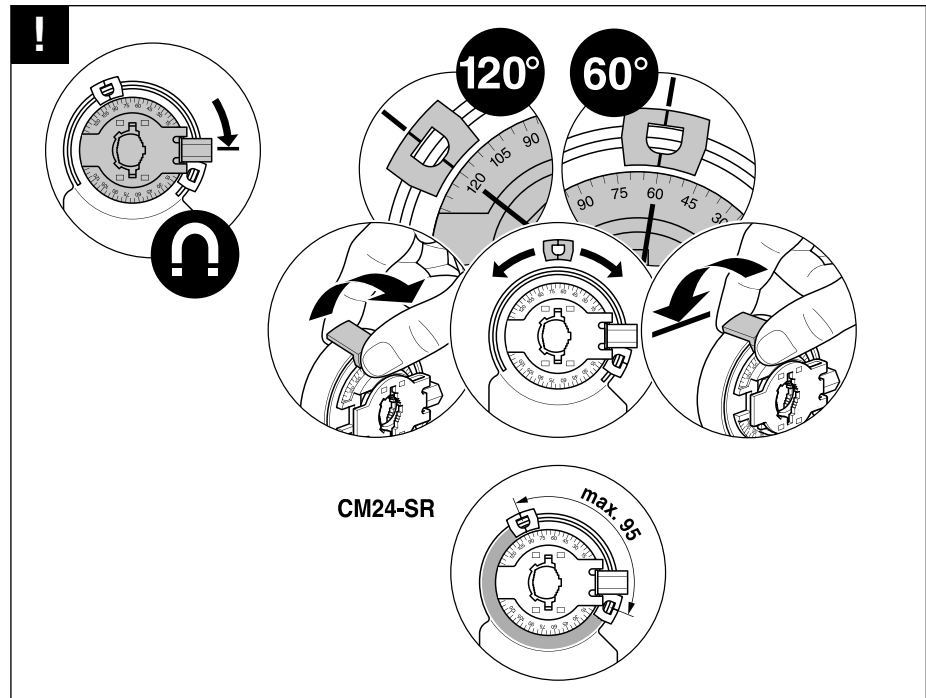
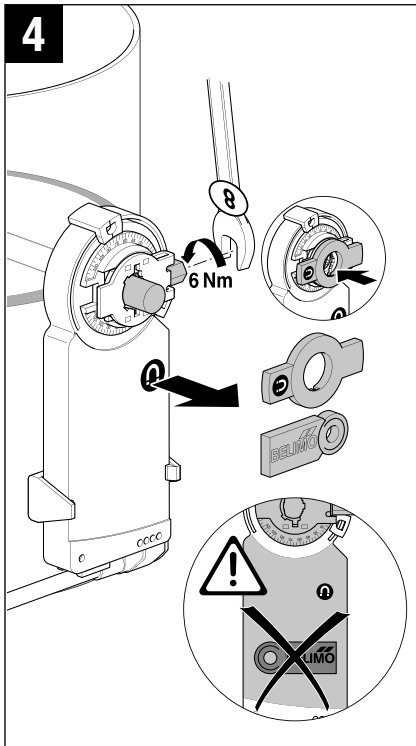
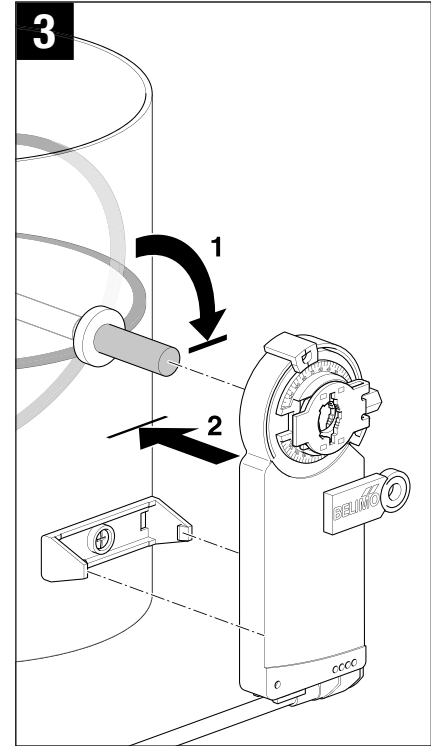
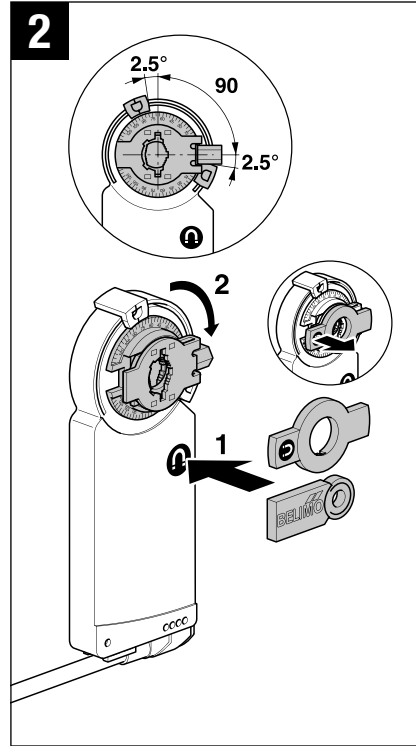
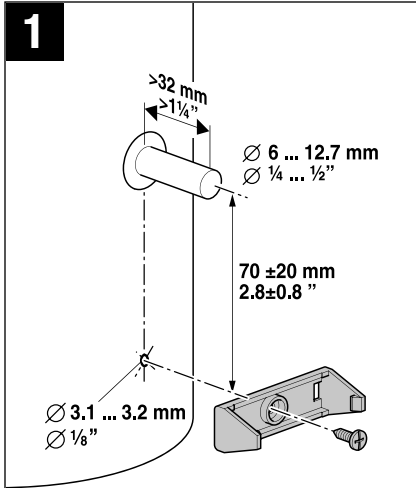

M40024 - 05/10 - Subject to change. © Belimo Aircontrols (USA), Inc.

#### Replacing Discontinued Belimo Actuators

When replacing an actuator, whether Belimo or other, be sure to consider the application parameters before selecting the replacement. The new product may not be the best fit for the application. Example would be a Belimo AM24 US mounted to a valve linkage. The direct replacement of the actuator is AMB24-3. However, the AM24 US and the AMB24-3 are different lengths, the linkage would need to be replaced as well.

Instead of replacing the linkage the retrofit bracket Z-SMA and Z-GMA can be used to extend the location of the anti-rotation bracket to match the location of the anti-rotation bracket of discontinued Belimo actuators.

**NOTE:** LM and LMB are the same size.

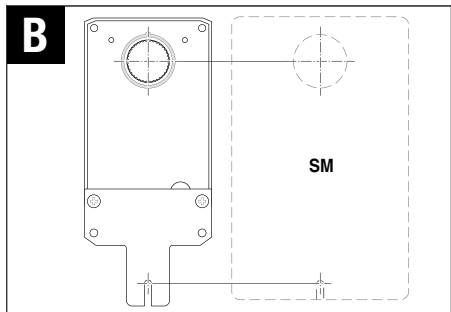
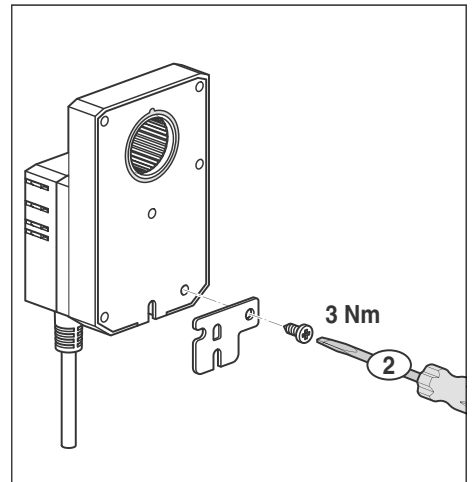
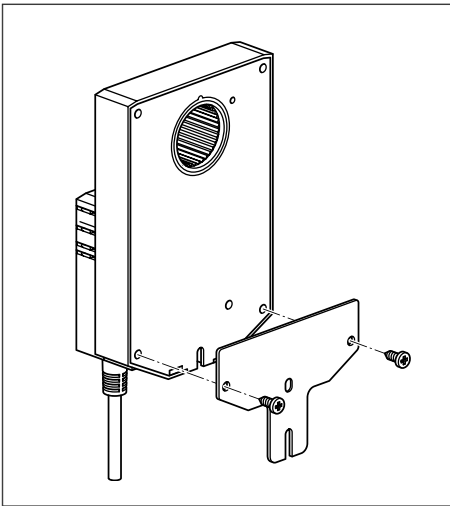
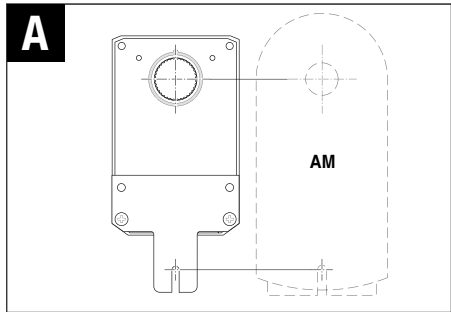
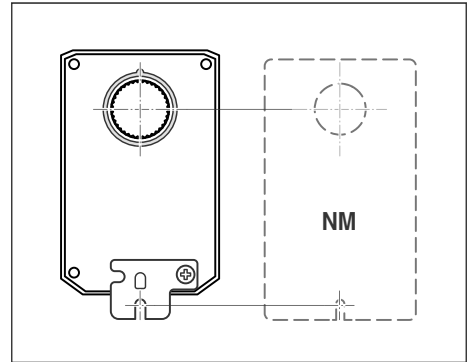
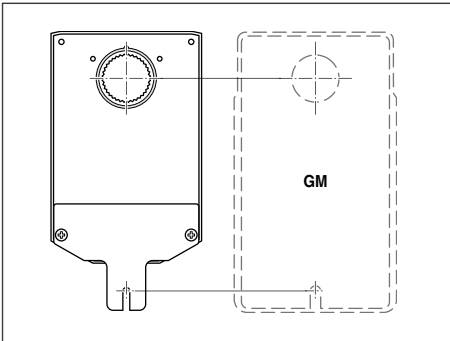
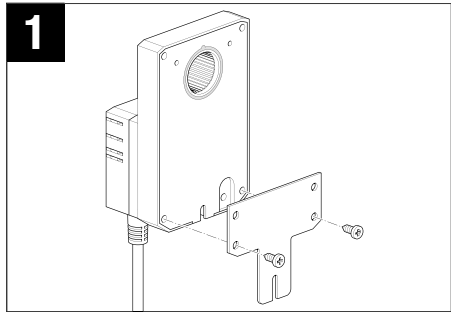
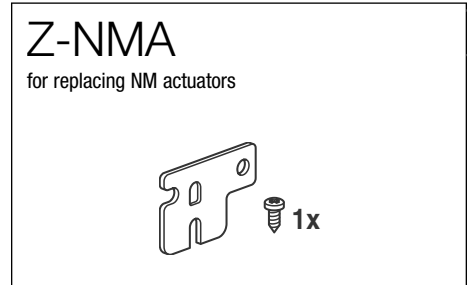
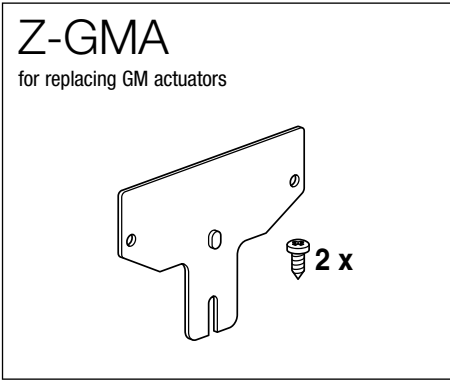
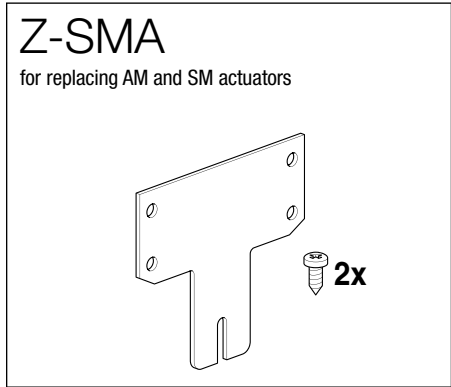

M40024 - 05/10 - Subject to change. © Belimo Aircontrols (USA), Inc.

### Electrical Operation

#### General

Belimo non-spring return actuators utilize Halomo sensorless Brushless DC motor technology developed by Belimo. The non-spring return actuators use this motor in conjunction with an Application Specific Integrated Circuit (ASIC). The Halomo ASIC provides the intelligence to provide a constant rotation rate to prevent damage to the actuator.

#### Initialization

When a power source is applied the motor carries out an initialization of the actuator. The purpose of this initialization is to determine the mechanical angle of rotation and to adapt the running time to the angle of rotation. When power is applied, the internal microprocessor recognizes that the actuator is at its full-safe position and uses this position as the base for all of its calculations.

#### Brushless DC Motor Operation

Belimo's Halomo sensorless brushless DC motor spins by reversing the poles of stationary electromagnets housed inside rotation permanent magnets. The electromagnetic poles are switched by a special ASIC developed by Belimo. Unlike the conventional DC motor, there are no brushes to wear or commutators to foul.

#### Motor Position Detection

Belimo's Halomo motor technology is a sensorless, brushless DC motor. The Halomo technology eliminates the need for potentiometers for positioning. The Halomo ASIC detects the spinning rotor by monitoring the back EMF of the motor poles. The ASIC counts these pulses and calculates position within 1/3 of a motor revolution.

#### Overload Protection

The Belimo non-spring return actuators are electronically protected from overload at all angles of rotation by digital technology in the ASIC. The ASIC circuitry constantly monitors the rotation of the brushless DC motor inside the actuator and stops the pulsing to the motor when it senses an overload. The motor remains energized and produces full rated torque when in overload.

The overload filtration helps increase the actuators installed life expectancy by filtering out unnecessary control signal changes or end-stop pulsing while in overload. This helps ensure that dampers are fully closed and that edge and blade seals are always properly compressed.

### Control Accuracy and Stability

All Belimo actuators have built-in brushless DC motors which provide better accuracy and longer service life.

Belimo non-spring return actuators are designed with a unique non-symmetrical deadband. The actuator follows an increasing or decreasing control signal with a 75 mV resolution. If the signal changes in the opposite direction, the actuator will not respond until the control signal changes by 175 mV. This allows these actuators to track even the slightest deviation very accurately, yet allowing the actuator to "wait" for a much larger change in control signal due to control signal instability.

**Actuator responds to a 75 mV signal when not changing direction from stop position.**

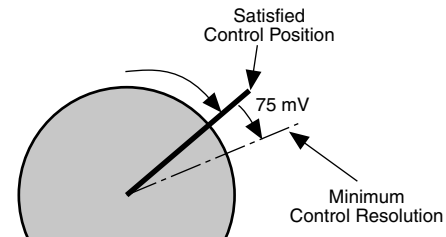

**Actuator responds to a 175 mV signal when reversing direction from stop position.**

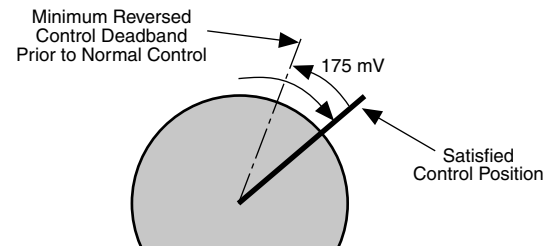



### Manual Override

The Belimo non-spring return actuators have a black, “manual override button” located on the top of the housing. Press this button and the gear train is disengaged so the damper shaft can be moved manually. Release the button and the gear train is re-engaged.

Use the manual override to test the installation without power. For tight shut-off the damper should close with 5° of actuator stroke left.

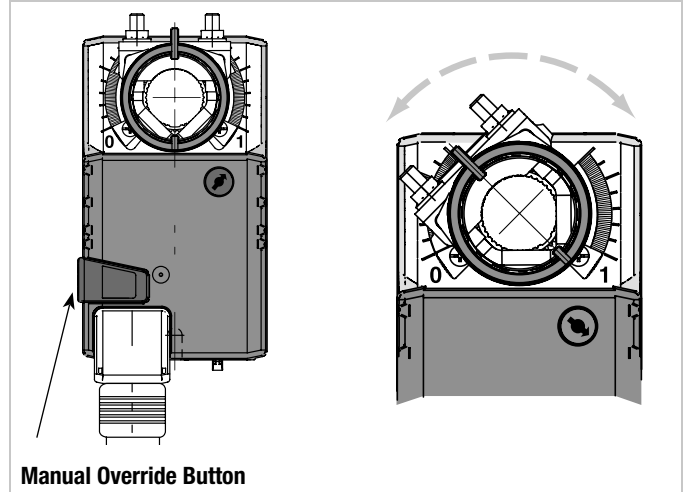

### Direction of Rotation Switch

Non-spring return actuators have a reversing switch on the cover. Switch position indicates start point. For the non-spring return, with the switch in position 1, the actuator rotates clockwise with an decrease in voltage or current. With the switch in position 0, the actuator rotates counterclockwise with an decrease in voltage or current.

The non-spring return rotates clockwise when the switch is in the 1 position and power is applied to wire #2. When power is applied to wire #3 the actuator rotates counterclockwise. Rotating the switch to 0 reverses the control logic.

During checkout, the switch position can be temporarily reversed and the actuator will reverse its direction. This allows the technician a fast and easy way to check the actuator operation without having to switch wires or change settings on the thermostat. When the check-out is complete, make sure the switch is placed back to its original position.

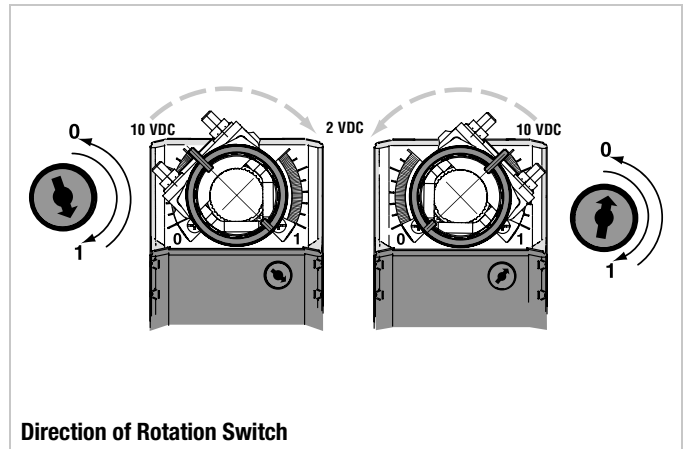

### Mechanical Angle of Rotation Limiting

The adjustable stops are needed when there is no damper stop or if you want the damper to stop rotating before it reaches its stops. The non-spring return actuators can be indefinitely stalled in any position without harm.

1. Loosen the two end stops with a No. 2 Phillips head screwdriver being careful not to unscrew the captive nut under the slot.
2. Move the stops (in 2.5° steps) to the desired position and re-tighten the screws.

